



Main Features:-

- ◆ Flanged PN16
- ◆ Bronze Body & Bonnet
- ◆ Cast Handwheel
- ◆ Rated PN16
- ◆ Temperature -10°C to 150°C

*Temperature and pressure determined by valve body, seat etc.



Suitable Applications & Approvals:



INDUSTRY

SERIES: 30062

MANUFACTURER: **AVOL**
INDUSTRIAL VALVES

VALVE DIMENSIONS

No	Name	Materials
1	Wedge	Bronze
2	Body	Bronze
3	Stem	Brass
4	Bonnet	Bronze
5	Stuffing Box	Bronze
6	Gland Packing	Teflon
7	Gland	Bronze
8	Gland Nut	Bronze
9	Hand Wheel	S.G Iron/Aluminium
10	Washer	Mild Steel

Size	L	H	W	D	T	Kg
1/2"	75	102	58	95	6	1.2
3/4"	85	115	58	105	6	1.78
1"	87	129	67	115	8	2.2
1 1/4"	100	140	73	140	8	3.4
1 1/2"	113	162	85	150	9	4.2
2"	125	188	110	165	11	5.6
2 1/2"	145	220	110	185	13	7.4
3"	161	249	133	200	13	10
4"	190	292	173	220	16	15.8

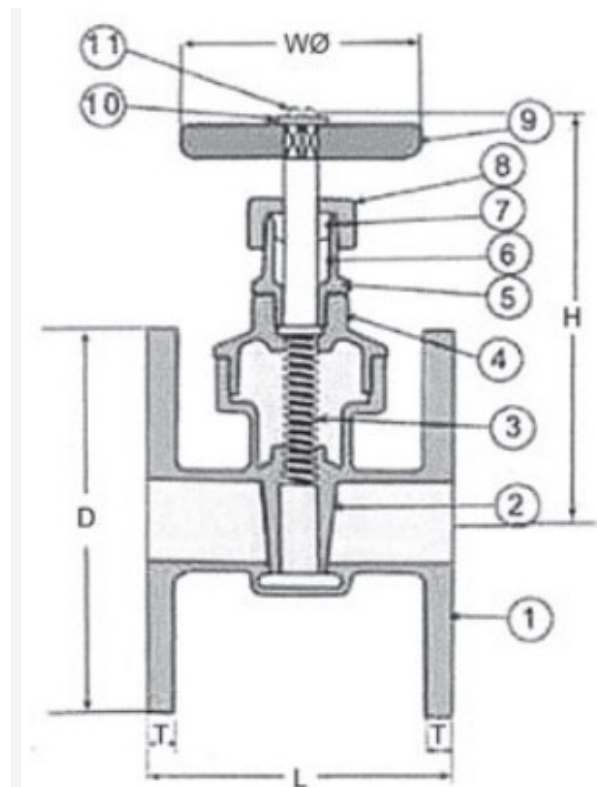

Cv—Flow rate in US GPM at a pressure drop of 1 PSI

Kv—Flow rate in m3 per hour at a pressure drop of 1 bar



T +44 (0)1386 552369

E sales@allvalves.co.uk

W www.allvalves.co.uk

F +44 (0)1386 554227